

L1219D

Universal Explosion-proof LED Lighting

Warning Light (Flashing Type or Rotating Type)



Net Weight: 7.7 kg (17.0 lb)



Protection

- Ex d IIB + H₂ T6 Gb
- Ex tb IIIC T55°C Db

Standards

JNIOOSH-TR-46-1
JNIOOSH-TR-46-2
JNIOOSH-TR-46-9
IEC 60079-0
IEC 60079-1
IEC 60079-31

Light Features

- Flashing / Rotation Type
- Light Color: Red, Blue, Green, Yellow

Technical Data

Rated Voltage (±10%)	24V / 100V / 110V / 120V / 200V / 208V / 220V AC
Watts (±10%)	10W (Max.)
Amps	10W 24V: 0.42A, 100V: 0.10A, 110V: 0.09A, 120V: 0.083A, 200V: 0.05A, 208V: 0.048A, 220V: 0.045A
Flash Rate	150 / Minute
Rotate Rate	160 rpm
Color of LED Light	Red / Yellow / Blue / Green
Ambient Temperature	-20°C ~ +40°C, T6
Beam Angle	X-110° / Y-110°
Frequency	50 / 60 Hz
Degree of Protection	IP68 / NEMA 6P
Material	<ul style="list-style-type: none"> • Enclosure: Aluminum alloy • Glass: Tempered glass
Entrance Thread	G 3/4" × 4 (Tall top cover)

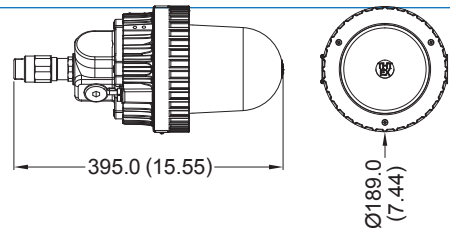

Dimension in Millimeters (inches)

Model Code

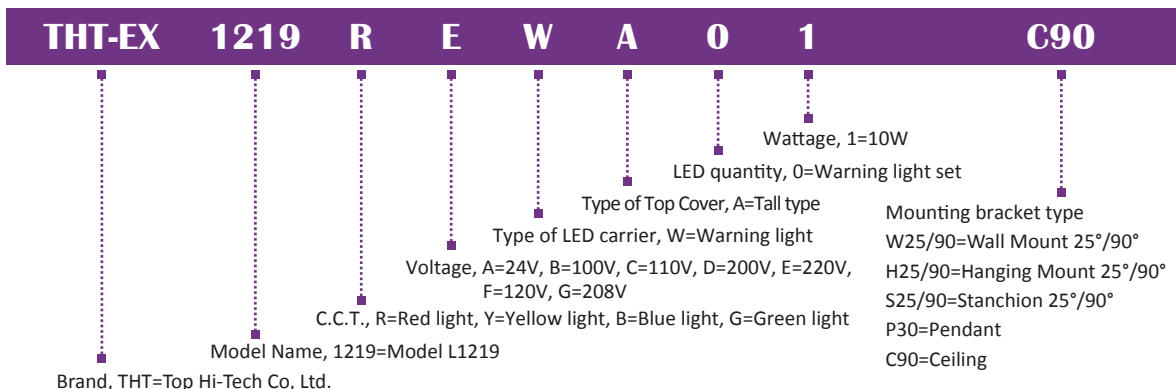

Mounting Option & Dimensions (All in mm)

Tall Top Cover (Standard Product)

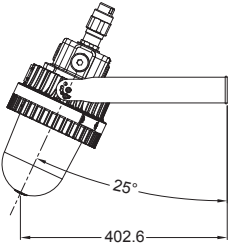
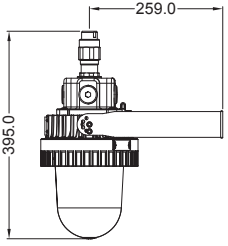
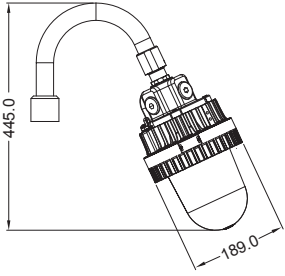
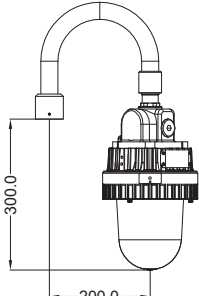
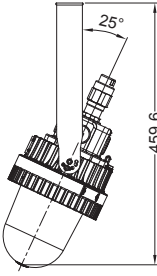
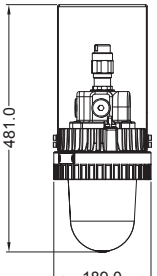
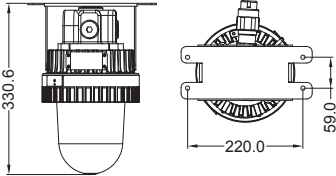
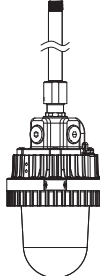
<p>Wall Mount 25° (W25)</p>  <p>8.2 kg (18.1 lb)</p>	<p>Wall Mount 90° (W90)</p>  <p>8.2 kg (18.1 lb)</p>	<p>Stanchion 25° (S25)</p>  <p>8.7 kg (19.2 lb)</p>	<p>Stanchion 90° (S90)</p>  <p>8.8 kg (19.4 lb)</p>
<p>Hanging Mount 25° (H25)</p>  <p>8.2 kg (18.1 lb)</p>	<p>Hanging Mount 90° (H90)</p>  <p>8.2 kg (18.1 lb)</p>	<p>Ceiling (C90)</p>  <p>9.3 kg (20.5 lb)</p>	<p>Pendant (P30)</p>  <p>8.2 kg (18.1 lb)</p>

Tall Top Cover (With Accessory "Guard")

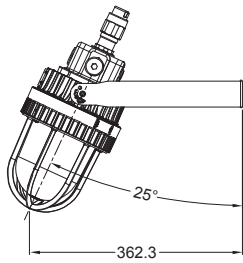
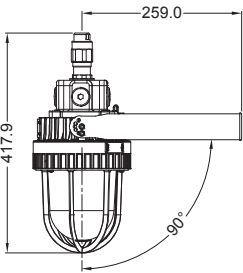
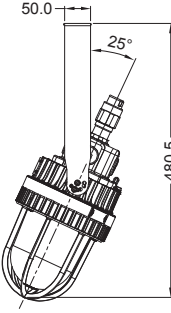
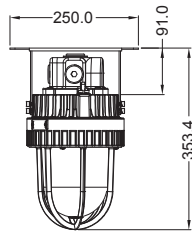
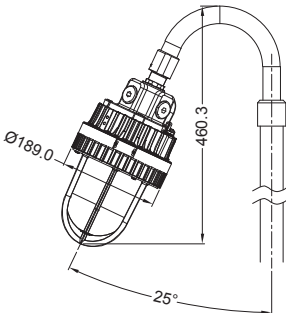
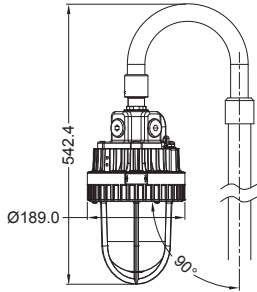
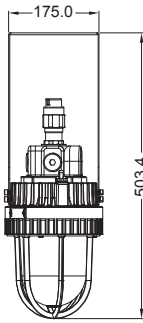
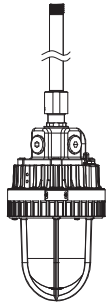
<p>Wall Mount 25° (W25G)</p>  <p>8.4 kg (18.5 lb)</p>	<p>Wall Mount 90° (W90G)</p>  <p>8.4 kg (18.5 lb)</p>	<p>Hanging Mount 25° (H25G)</p>  <p>8.4 kg (18.5 lb)</p>	<p>Ceiling (C90G)</p>  <p>9.5 kg (20.9 lb)</p>
<p>Stanchion 25° (S25G)</p>  <p>8.9 kg (19.6 lb)</p>	<p>Stanchion 90° (S90G)</p>  <p>9.0 kg (19.8 lb)</p>	<p>Hanging Mount 90° (H90G)</p>  <p>8.4 kg (18.5 lb)</p>	<p>Pendant (P30G)</p>  <p>8.4 kg (18.5 lb)</p>