

WF24 Tapered 0.260" Bore Thermowell

Model Code

WF24 - T1 - T2 - T3

WF24	Tapered - 0.260" Bore - Wrench Flat Threaded		
T1	Process Connection	"A" (Root)	"B" (Tip)
1/2	1/2" NPT	0.625"	0.500"
3/4	3/4" NPT	0.875"	0.750"
1	1" NPT	1.063"	0.750"
Other	Consult factory		

T2	Material		
304	304/304L stainless	800	Incoloy 800
316	316/316L stainless	A105	A105 carbon steel
310	310 stainless steel	LF2	A350 LF2
600	Inconel 600	HAC	Hastelloy C276
625	Inconel 625	Other ²	Consult factory

T3	Specify "U" Length (inches)
"inches"	Specify length in inches

Outline & Dimensions

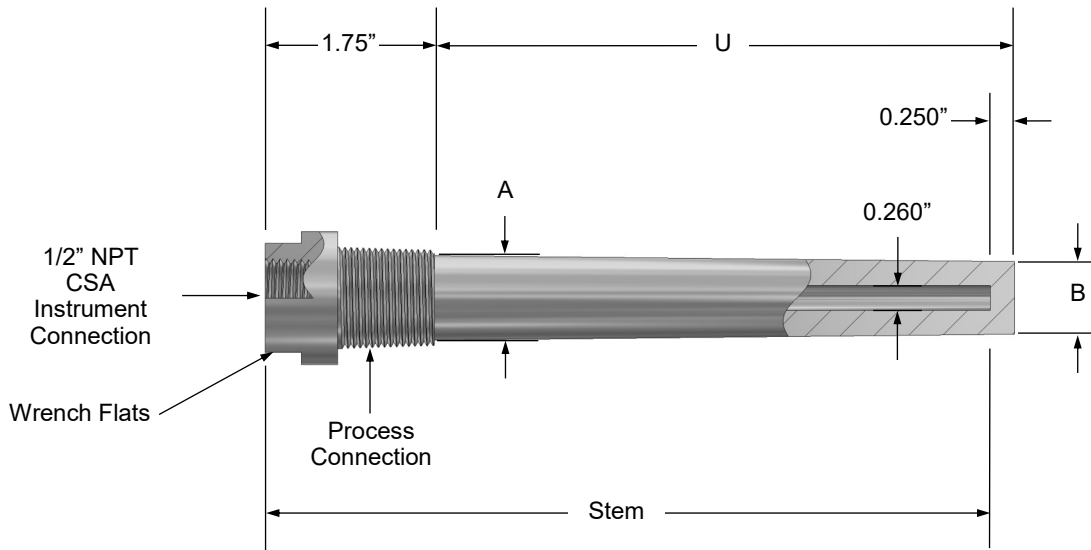

Special option codes specified as come complete with (c/w) thermowell if required

Code	Description
SSPC	Stainless steel plug and chain
BRPC	Brass plug and chain
OVRL	Overlay (details to be specified)

NOTES:

1. Part number example: WF24-3/4-316-2.5 or WF24-1-316-6 c/w SSPC
2. Canadian Registration Number (CRN) available for most common alloys, consult factory

