

Table of contents

	Page
Safety notes/ Technical support	2

Overview	3

Technical Data	4

Accessories	4

Electrical installation	5

Commissioning	10

Visualisation - Operation	11

Subject to technical change.

We assume no liability for typing errors.

Safety notes / Technical support

Notes

- Installation, maintenance and commissioning must be carried out only by qualified technical personnel.
- The product must be used only in the manner outlined in this instruction manual.

Special attention must be paid to warnings and notes as follows:



WARNING

Relates to a caution symbol on the product and means, that a failure to observe the necessary precautions can result in death, serious injury and/ or considerable material damage.



WARNING



Relates to a caution symbol on the product and means, that a failure to observe the necessary precautions can result in death, serious injury and/or considerable material damage.

This symbol is used, when there is no corresponding caution symbol on the product.

CAUTION

A failure to observe the necessary precautions can result in considerable material damage.

Safety symbols

In manual and on product	Description
	CAUTION: refer to related documents (manual) for details.
	Earth (ground) Terminal
	Protective Conductor Terminal

Technical support

Please contact your local supplier (see www.uwt.de for address). Otherwise you can contact:

UWT GmbH
 Westendstr. 5
 87488 Betzigau
 Germany

Tel. 0049 (0)831 57123-0
 Fax. 0049 (0)831 76879
info@uwt.de
www.uwt.de

Overview

Level monitoring and visualisation via touch panel

- Standardized system up to 15 silos
- Visualisation and operation via 7" touch panel (coloured, 800 x 480 pixel)
- Software language german or english
- Password protected
- Data in percentage, height, volume or weight
- Trend display, data storage
- Evaluation of the analogue 4-20 mA signals of any sensors, as well as Modbus RTU of the UWT-systems
- Different input signals within the same system is possible
- Implementation of full detectors
- Fill control via full alarm signal (Buzzer)

NT 4600 Basis unit

The heart of the NT 4600 is a touch panel, which runs the visualisation software. All fill level control and display functions can be operated via the touch panel. Access is password protected. The electromechanical lead system can be started by the visualisation software.

Modbus converter

- For connection of 4-20 mA/ 2-wire sensors and full detectors
- On each converter up to 4 sensors and 4 full detectors can be connected
- Provided for mounting directly on the silo

Integration of full detector incl. alarm "silo full"

- Buzzer with reset button (supplied loose, for outdoor mounting)
- One unit for all connected silos
- Alarm happens, if one of the silos gets full
- Reset of the alarm
- Provided for mounting directly on the silo

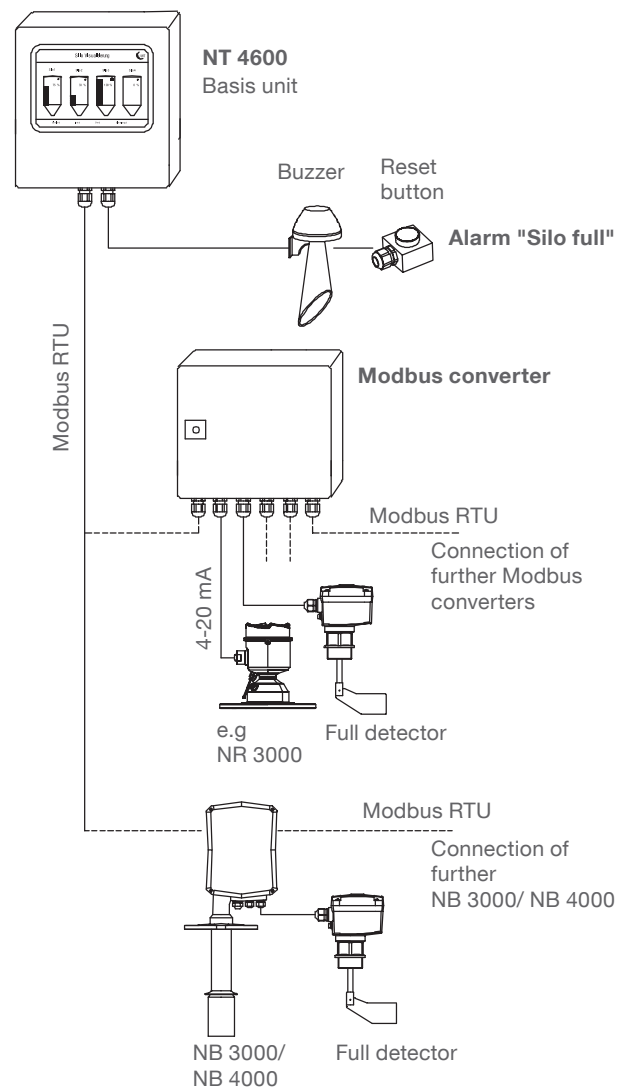

Technical Data / Accessories

Technical data

Dimensions	NT 4600, Modbus converter:	300 x 300 x 155 mm (W x H x D)
Dimensions (Touch panel without cabinet)	Touch panel Panel cutout	200 x 146 x 34 mm 192 x 138 mm
Mounting	NT 4600, Modbus converter:	wall mounting
Material	NT 4600, Modbus converter:	steel plate
Ingress protection	NT 4600, Modbus converter:	IP65
Ambient temperature	NT 4600: Modbusumsetzer:	0 .. +50°C -25 .. +70°C
Power supply	NT 4600, Modbus converter: NR 3000: NB 3000/ 4000: Full detector:	115 V or 230 V 50/ 60 Hz (integrated power converter 24 V DC) supplied by Modbus converter 115 V or 230 V AC, connection is made on site Connection either on NB 3000/ NB 4000 resp. Modbus converter. In this case the supply voltage must be equal to NB 3000/ NB 4000 resp. Modbus converter. Alternative it is possible to connect on site.
Power consumption	NT 4600, Modbus converter: Connected level sensors:	20 VA see documentation of the respective sensors
Signal output full detector	Floating contact is required	

Terminal box

Intermediate terminals for the wires leading to the silo (mounting e.g. on the silo frame).
 Applicable for cables of level (Modbus or 4-20 mA), limit switch, buzzer, reset button

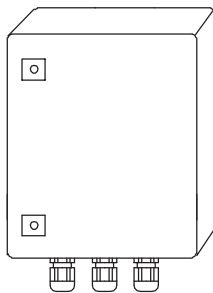

Technical data

Dimensions	200 x 300 x 120 mm (W x H x D), for wall mounting	
Material	steel plate	
Ingress protection	IP65	
Ambient temperature	-25 .. +60°C	
Terminal blocks	15 pieces grey, 5 pieces blue, 5 pieces green/yellow; each terminal implements 3 cable inlets 2.5 mm ² , mounted on top hat rail	
Cable glands	6 pieces M20 x 1.5	2 pieces M25 x 1.5

Electrical installation

! Safety Instructions

Handling	In case of improper handling or handling malpractice, the electric safety of the device cannot be guaranteed.
Installation regulations	The local regulations or VDE 0100 (Regulations of German Electrotechnical Engineers) must be observed.
Fuse	Use a fuse as stated in the connection diagrams.
RCCB protection	In case of a fault, the supply voltage must be automatically switched off by a RCCB protection switch to protect against indirect contact with dangerous voltages.
Power supply switch	A voltage disconnection switch must be provided near the device.
Wiring diagram	The electrical connections are made in accordance with the wiring diagram.
Supply voltage	Compare the supply voltage applied with the specifications given on the name plate before switching the device on.
Cable gland	Make sure that the screwed cable gland safely seals the cable and that it is tight (danger of water intrusion). Cable glands that are not used have to be sealed with a blanking element.
Field wiring cables	All field wirings must have insulation suitable for at least 250 V AC. The temperature rating must be at least 80°C (176°F).
Installation in Hazardous Locations	The NT 4500 and the Mobus converter are not permitted for installation in Hazardous Areas. Observe the valid regulations for wiring in Hazardous Areas, if the NB 3000/ NB 4000 is installed in Hazardous Areas.

Modbus network

General wiring of a Modbus network

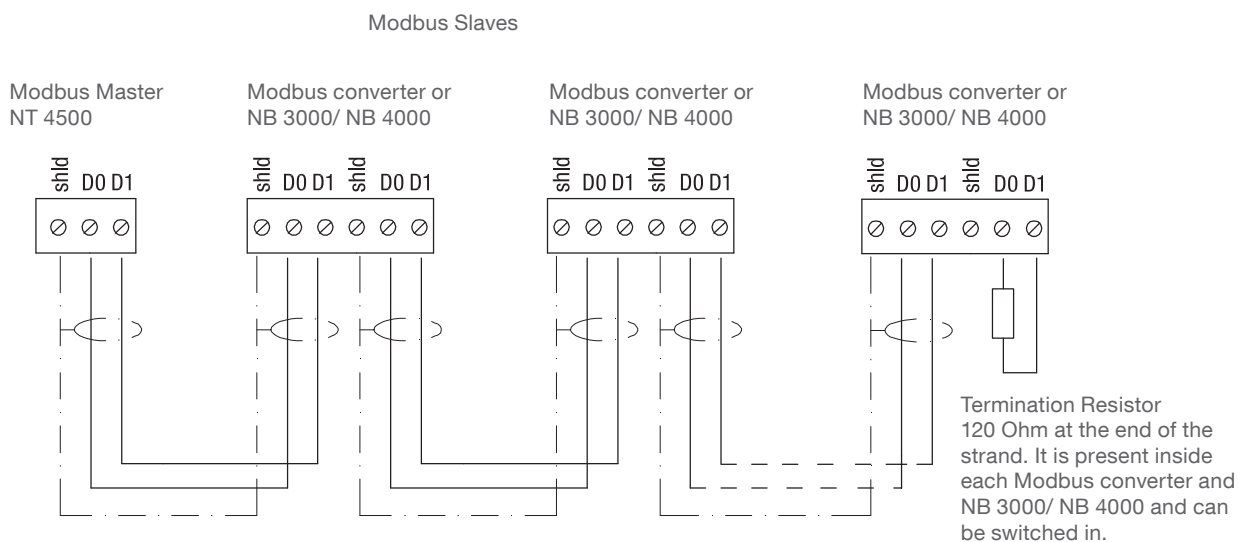

Other used notations:
 D0 = Rx-/Tx- = A
 D1 = Rx+/Tx+ = B

Terminals D0 as well as D1 are internally connected.

Note:

If required it is possible to split the Modbus network into two strands. Both strands are wired in parallel at the Modbus Master. A termination resistor must be present at the end of each strand.

Electrical installation

Cable recommendations for Modbus network

Shielded cable

Functionality up to 50 m
 Manufacturer: Lapp, Type UNITRONIC LiYCY 2x 0.34, Art.no: 0034502

Twisted pair cable

Functionality up to 1,000 m
 Manufacturer: Lapp, Type UNITRONIC BUS CAN 1x 2x 0.34, Art.no: 2170263

UV-protection hose with threaded hose coupling M20 x 1.5

UV protection for Modbus cable
 Manufacturer: Flexa, Type Rohrflex PA6, Art.no: 0233.202.012 and Type RQG1-M, Art.no: 5020.055.018

ATEX-protection hose with threaded hose coupling M20 x 1.5

For installation of Modbus cable in ATEX Zone 21
 Manufacturer: PMA, Type ESX, Art.no: ESXT-12B.50 and Type END, Art.no: BEND-M202GT

NT 4600

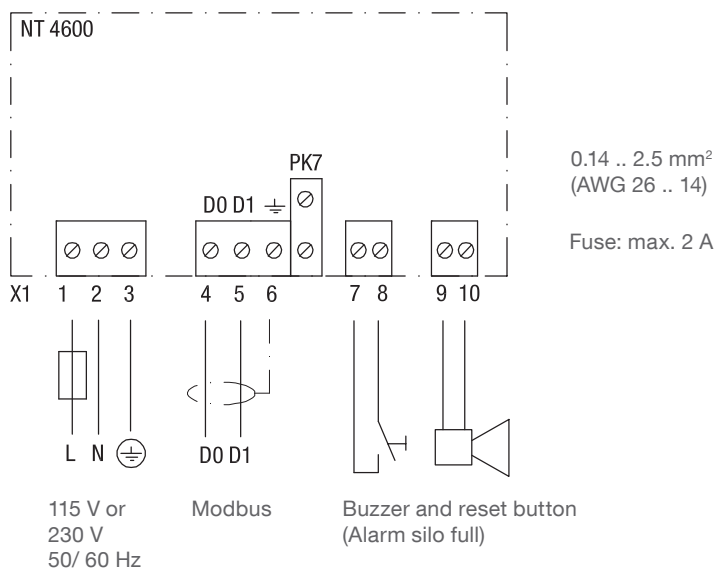

Wiring of Touch panel

Only relevant if pos.1 A "Touch panel without control cabinet" was ordered

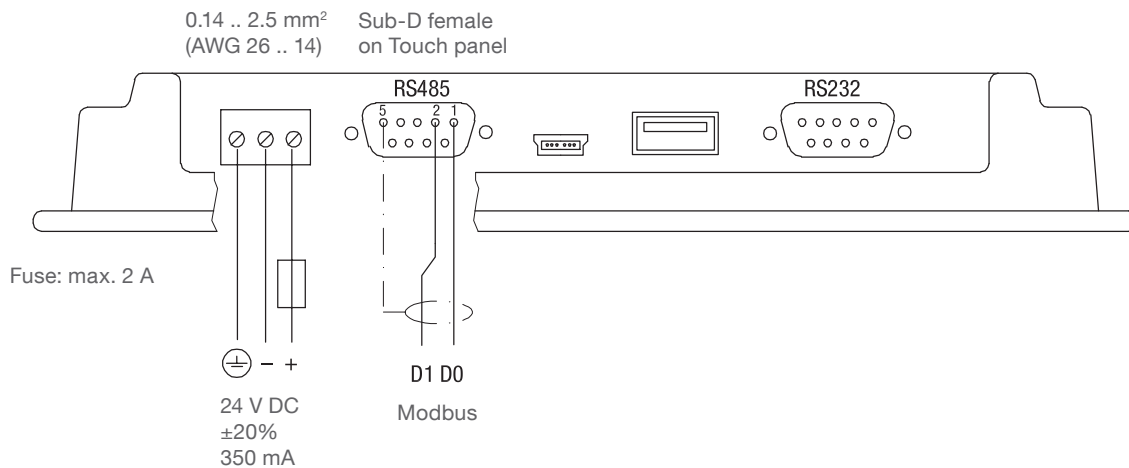

Electrical installation

NB 3000/ NB 4000

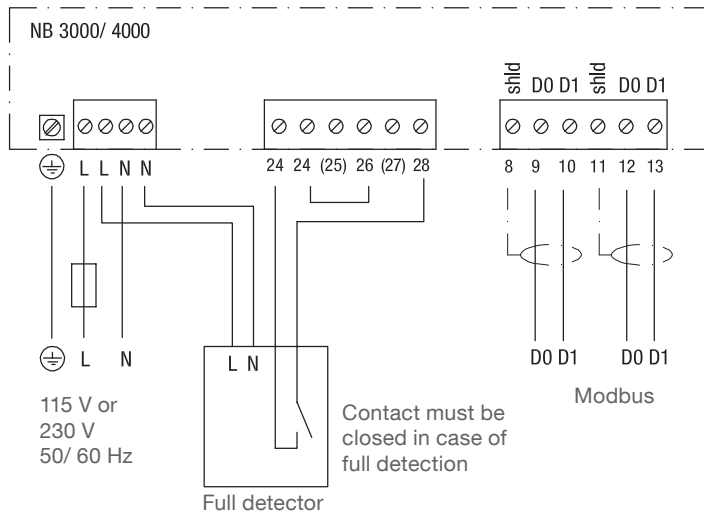

0.14 .. 2.5 mm²
 (AWG 26 .. 14)

Fuse: max. 10 A

Electrical installation

Setting: Biasing and Termination Resistor

For use of NB 3000/ NB 4000 units in a external Modbus network, it is possible to set Biasing and Termination Resistor on each unit as required.

NB 3000

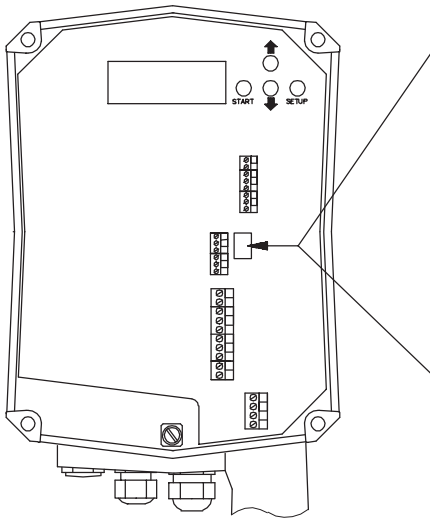

Version with Jumper

Biasing	OFF*	OFF	ON
Termination Resistor	OFF*	ON	ON

Version with DIP switch

Biasing	OFF*	OFF	ON	ON
Termination Resistor	OFF*	ON	OFF	ON

*factory provided

DIP Switch position:
 Top view Side view

NB 4000

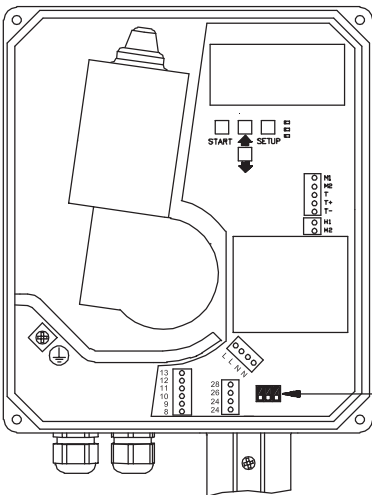

Biasing	OFF*	OFF	ON	ON
Termination Resistor	OFF*	ON	OFF	ON

*factory provided

DIP Switch position:
 Top view Side view

Electrical installation

Modbus converter

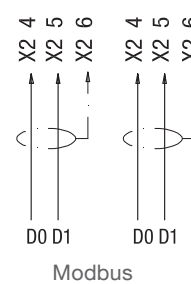
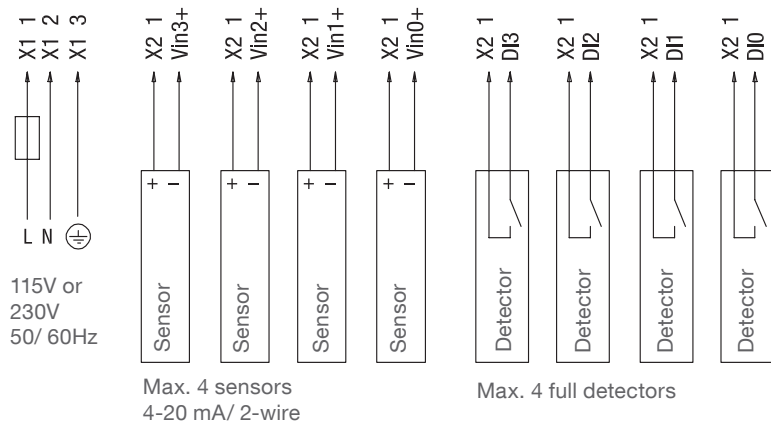
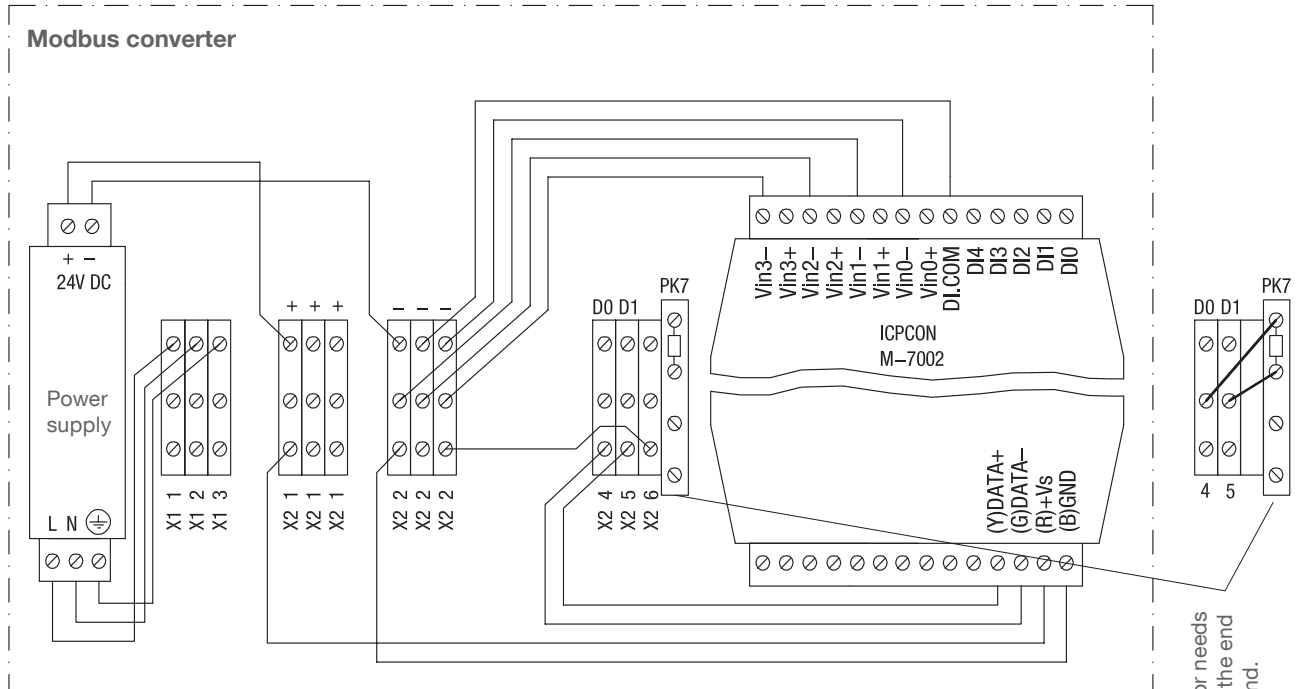

Termination Resistor needs to be connected at the end of the Modbus strand.

Fuse: max. 10 A

Terminals M-7002: 0.14 .. 1.5 mm² (AWG 26 .. 16)
 Other terminals: 0.14 .. 2.5 mm² (AWG 26 .. 14)

The stated wiring inside the Modbus converter is factory provided.

Commissioning

1. Generation of a synoptical table

Commissioning is facilitated if an overview of the connected sensors is made in advance. The table shows an example of a project with 10 silos and mixed configuration of Nivobob NB 3000 and NR 3000 radar as well as implementation of full detectors:

Silo	Sensor	Modbus ID	Modbus converter*		
			Channel	Terminal of 4-20 mA sensor	Terminal of full detector
1	NB 3000	3	n/ a	n/ a	n/ a
2	NB 3000	4	n/ a	n/ a	n/ a
3	NB 3000	5	n/ a	n/ a	n/ a
4	NB 3000	6	n/ a	n/ a	n/ a
5	NR 3000 4-20 mA sensor	1	0	Vin0+	DI0
6	NR 3000 4-20 mA sensor	1	1	Vin1+	DI1
7	NR 3000 4-20 mA sensor	1	2	Vin2+	DI2
8	NR 3000 4-20 mA sensor	1	3	Vin3+	DI3
9	NR 3000 4-20 mA sensor	2	0	Vin0+	DI0
10	NR 3000 4-20 mA sensor	2	1	Vin1+	DI1

* see page 9 as well as 17 - 18 under "Input Signal"

2. Check the wiring

Make sure that the Modbus network is wired, set the Modbus Termination Resistor (and for NB 3000 the Biasing), check that the Ethernet connection is available (see "Electrical installation" from page 5 onwards).

3. Perform the basic settings for the visualisation

- Basic Settings - User (see page 13).
To do further settings, the userlevel must be set to Level 2.
- Basic Settings - System (see page 14).

4. Perform the settings of the silo data and of the connected sensors

With the following settings, the connected sensors are addressed via the visualisation and give a real measurement result. For this settings the above mentioned synoptical table is helpful:

- Silo Settings (see page 16).
- Sensor Settings (see page 17 - 18).
Note: All units are presetted to 19200 Baud. Thus no setting is required.

Visualisation - Operation

Overview page (Silo overview)

Display of level, full detector, information regarding silo and error messages

User Level 0 or higher

The selected number of silos (as defined on page 14) is presented. If more than 3 silos are defined, a button appears for progression to the next or previous page.

The level is stated according to the unit as selected under "unit level" (see page 16)
 The colored points display the full detection as defined under "Full detector" (see page 17 - 18).

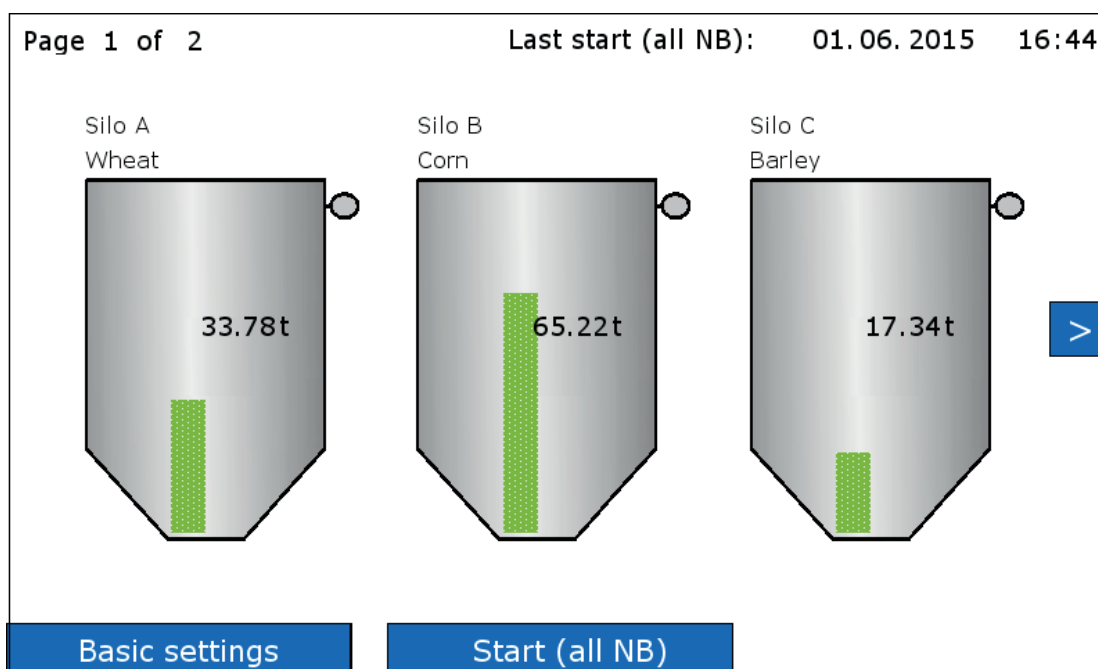

Silo Single View (pressing on a silo)

The single view for the respective silo will open (see page 12).

Basic settings

see page 13 to 15

START (all NB)

User Level 1 or 2.

Starts the measurement of all connected Nivobobs. If more than 3 silos are defined, the measurements of the silos not displayed on the screen are started as well.

While the measurement is running, a green arrow appears in each silo.

In the top line the date and time of the last measurement is displayed.

Measurement start is not possible due to one of the following reasons:

Under "Sensor-settings" the selection "Sensor Nivobob" is not present (see page 17).

The "Modbus for silo" is set to "inactiv" (see page 17).

Display "Blocked Start": The Nivobob Measurement Start is set to "no" (see page 17).

Display "Blocked 24 - 26": The bridge between terminal 24 - 26 at the Nivobob ist open. See Nivobob user manual.

Horn reset

Reset of the full signal (horn). The button appears only, if the horn is activated.

Possible other messages:

"Offline": The "Modbus for silo" is set to "inactiv", thus the respective silo has no valid measurement (see page 17).

"Modbus": The Modbus network is not working. See items under commissioning (page 10).

Further diagnostic messages may appear. If so, the messages implement comments for reason and possible measures.

Visualisation - Operation

Page "Silo Single View"

Display of trend and forward to the settings of silo and sensor

User Level 0 or higher

The page opens by pressing on a silo in the Overview page (Silo overview).

The level is displayed similar to the Overview page (Silo overview).

The selected "Time span for trend" defines the time which is displayed in the diagram. Previous data are not stored. After a power failure the trend starts from the beginning. With use of a USB stick the data can be readout from the stick.

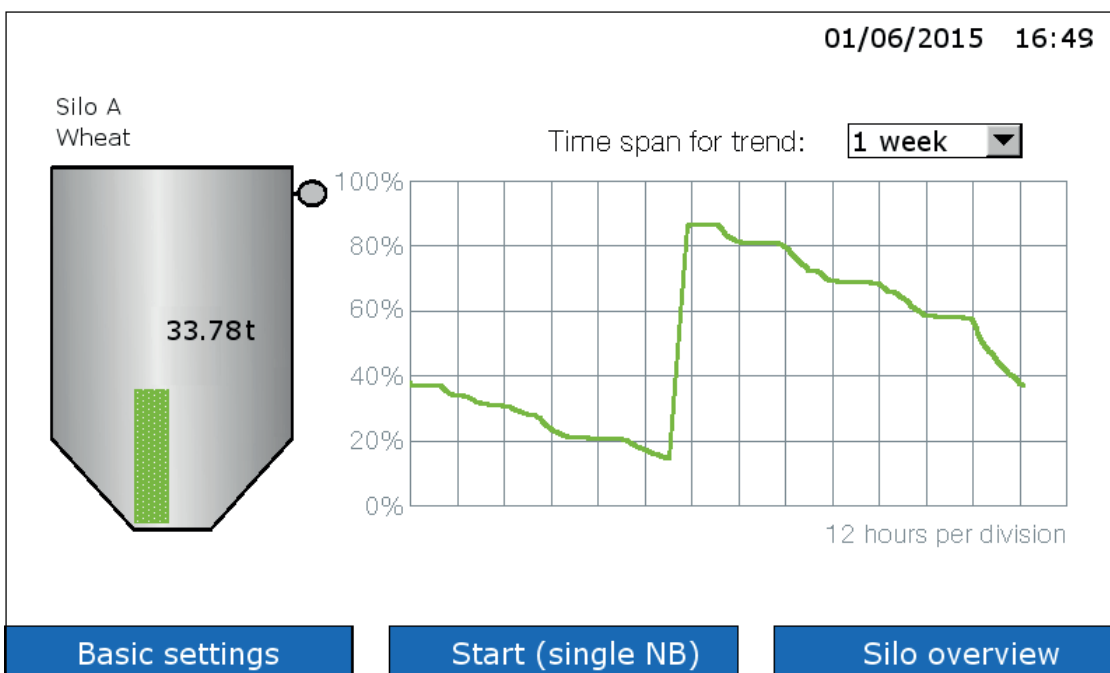

START (single NB)

Starts the measurement of the Nivobob only for this silo. While the measurement is running, a green arrow appears in the silo.

If no START button appears, the measurement start is not possible due to one of the following reasons:

Under "Sensor-settings" the selection "Sensor Nivobob" is not present (see page 17).

The "Modbus for silo" is set to "inactiv" (see page 17).

Display "Blocked Start": The Nivobob Measurement Start is set to "no" (see page 17).

Display "Blocked 24 - 26": The bridge between terminal 24 - 26 at the Nivobob ist open. See Nivobob user manual.

Pressing on the silo

Leads to the page "Silo Settings" (see page 16) and "Sensor Settings" (see page 17 - 18) for this silo.

Possible other messages:

"Offline": The "Modbus Enable" is set to "inactiv", thus the respective silo has no valid measurement (see page 17).

"Modbus": The Modbus network is not working. See items under commissioning (page 10).

Further diagnostic messages may appear. The messages implement comments for reason and possible measures.

Visualisation - Operation

Page "Basic settings - User"

Selection of user rights and password

User rights overview

Depending on the selected userlevel the following features are available:

Feature	Level 0	Level 1	Level 2
Overview page (Silo overview)	x	x	x
Silo single view	x	x	x
Horn reset (full detection)	x	x	x
Measurement start Nivobob		x	x
Page "Basic settings"			x
Page "Silo settings"			x
Page "Sensor settings"			x
Password change for Level 1 and 2			x

Change of user rights

Select the userlevel to be changed to, enter the password and press "Change".
 Factory provided the password for all levels is set to "0".
 If the change was successful, the box changes its colour to green, otherwise to red.
 If the password is forgotten, please contact the supplier.
 Note: Level 3 und 4 are used for service reasons (not available).

Actual userlevel: Level 2

Change to:

Password:

Password change

Factory provided the password for all levels is set to "0".
 To change a password requires to be logged in Level 2, where the button "Edit password" appears. Press this button and select the level for which the password shall be changed.

For Level 0 the password can not be changed, it remains "0".
 For Level 1 and 2 the new password may be one-digit to six-digit.
 If the password change was successful, the box changes its colour to green, otherwise to red.

Editing for:

Old password:

New password:

Password confirmation:

Visualisation - Operation

Page "Basic settings - System"

Setting of date, time, country-specific units, number of displayed silos , measuring interval of Nivobob, horn, USB data storage

User Level 2

System Settings		Firmware v1.0	01/06/2015 16:27
Date - time Day <input type="text" value="1"/> Month <input type="text" value="6"/> Year <input type="text" value="2015"/> Hour <input type="text" value="16"/> Minute <input type="text" value="27"/> Second <input type="text" value="56"/> Language <input type="text" value="english"/> Units <input type="text" value="feet"/>		Amount of silos <input type="text" value="5"/> Measuring interval Starttime [hh:mm] <input type="text" value="5:00"/> Interval [hh:mm] <input type="text" value="14:00"/> Horn connected no <input type="checkbox"/> yes <input checked="" type="checkbox"/>	
		USB Data storage no <input type="checkbox"/> yes <input checked="" type="checkbox"/> Interval [hh:mm] <input type="text" value="0:30"/> Storage [MB/year] <input type="text" value="2.05"/>	
Basic settings		Silo overview	

Date - time

Setting of the actual date and time.

Language

Setting of the software language.

Units

Setting of the unit for the silo dimensions in page "Silo settings" (see page 16).

Amount of silos

Definition of the total number of silos for the visualisation.

Measuring interval

Activation of automatic measurement starts of the Nivobobs. The measurement starts happens daily, the first time at the setted Starttime (time of day), then regularly repeated with the setted Interval (hours : minutes).

If the Interval is set to 0, no measurement starts will happen.

Horn connected

Setting, if a horn (which is activated with a full detection) is connected. This setting is required to adjust the internal data processing to the horn functionality.

USB data storage

A USB stick can be plugged in at the bottom side of the panel. The data storage starts automatically after the switch is set to "yes".

Trend data for all silos are stored to the USB stick in .csv format.

The stored level values are volume related (considering the silo cone), in per mil (0 - 1,000 per mil). Storage in absolute values like tons, cubic meter or meter is not possible.

A new file is created for every month.

The transfer of data to the USB stick is done automatically every 10 minutes.

Interval:

The Interval defines the time until the next measurement value is stored (hours : minutes). Minimum Interval is one minute. With setting 00:00 no storage will happen.

Storage:

States the required storage space of the USB stick (depending on the selected Interval).

Visualisation - Operation

Page "Basic settings - Diagnostics Nivobob"

Readout of diagnostics data from Nivobob

User Level 2

The data are used for diagnostic reasons.

Modbus ID Read
01/06/2015 16:11

Setup	Diagnostics
40001 - M_LANGUAGE	40026 - M_TOTAL_CYCLES
40002 - M_UNIT	40044 - M_TOTAL_CYCLES_H
40003 - M_MAX_MOVE_DIST	40028 - M_CYCLES_LEFT
40004 - M_SILO_HEIGHT	40050 - M_CYCLES_LEFT_H
40005 - M_AIR_DIST	40029 - M_TOTAL_RUN_TIME
40006 - M_CONE_HEIGHT	40048 - M_TOTAL_RUN_TIME_S
40022 - M_TIMER	40031 - M_RUN_TIME_LEFT
	40053 - M_FAILURE
	40054 - M_MAINTENANCE
Measurement	Communication
40051 - M_START	40034 - M_PROTOCOL
40046 - M_DISTANCE	40035 - M_ADDRESS
40055 - M_VOLUME	40036 - M_BAUDRATE
40052 - M_INHIBIT	
40045 - M_STATUS	
40057 - M_FULL_DETECTOR	

Basic settings
Silo overview

Modbus ID

Enter the ID number (Modbus address) of the Nivobob which shall be readout.
 After pressing "READ" all Modbus registers of the related Nivobob are readout and displayed.
 Please see user manual of Nivobob for further explanation of the registers.
 To write data into the Nivobob registers is not possible.

Visualisation - Operation

Page "Silo settings"

Settings for silo related data

User Level 2

The page opens by pressing on the silo in the page "Silo single view".

Silo settings
Sensor settings
01/06/2015 16:26

Silo description

Name:

Content:

Article no.:

Silo data

H: ft

K: ft

L: ft

D1: ft

D2: ft

Silo shape

round angular

Unit level

Bulk density

lb/ft³

Max. value: 74.41 tns

Basic settings
Back
Silo overview

Silo description

The silo can be labeled with any text for silo name, content and article number.

Silo data and Silo shape

With the setted data the software calculates the volume related measurement.

Unit level

The selected unit is stated inside the silos, see page 11 and 12.

Bulk density

If a weight is selected in "Unit level", it is required to enter the density of the bulk material to enable the weight calculation.

Max. value

Display of the max. calculated content according to above setted data.

Visualisation - Operation

Page "Sensor settings"

Settings for sensor related data

User Level 2

The page opens by pressing on the silo in the page "Silo single view".

a) With use of Nivobob

Sensor

Setting to "Nivobob".

Input Signal

Modbus for silo:

It is possible to switch off single silos from the Modbus network (e.g. for revision) by setting the related Modbus ID inactive. If so, the other silos stay active. Inside the related silo it will be stated "Offline".

Modbus ID:

Input of the Modbus ID (Modbus address) of the Nivobob.

The Modbus address of the Nivobob is setted in the Nivobob communication menu (see user manual of Nivobob). It is reasonable to use the address 1 for the first device, then ascending to 2, 3, etc. With mixed use of Modbus converters the first addresses of the Modbus converters are already preset (see next page), the Nivobob addresses must then be allocated above these. Optional (with selection code 33) the Nivobob devices are delivered with already preset address.

Full detector

If a full detector is connected, it is read with setting to "Modbus" (see electrical installation page 7 for connection to NB 3000/ NB 4000). If "value" is selected, the message for full detection is activated, if the entered value (in percent) is exceeded by the material level.

Nivobob

Enable start:

Measurement start can be blocked by setting to "no", for example while a silo is beeing filled. Inside the related silo it will be stated "Blocked Start".

Max. move distance:

Setting of the max. move distance of the sensor weight.

By pressing "read" the value is readout from the Nivobob and displayed.

By setting a value and pressing "write" the setted value is written into the Nivobob.

Note: The setting of the max. move distance can also be done directly at the Nivobob.

Note: Further settings inside the Nivobob menu are not relevant, since the visualisation requires only the measured distance from the Nivobob and calculates to a volume based display.

b) With use of 4-20 mA sensor (connected via Modbus converter)

Programming of the 4-20 mA sensor:

The connected sensor must be set as follows:

- 4 mA must correspond to the level value 0% (see "Silo settings", page 16).
- 20 mA must correspond to the level value 100%.

Note to NR 3000: H and L are related to the fixing flange.

- The sensors needs to have a linear level signal (relation between the signal output and level in the silo). The volume-based calculation is performed in the visualisation only.

Sensor

Setting to "4-20 mA".

Input Signal

Modbus for this silo:

It is possible to switch off single silos from the Modbus network (e.g. for revision) by setting the related Modbus ID inactive. If so, the other silos stay active. Inside the related silo it will be stated "Offline".

Modbus ID:

Input of the Modbus ID (Modbus adress) of the Modbus converter.

The Modbus converters are factory presetted to address 1 for the first Modbus converter, then ascending to 2, 3, etc. The settings can not be changed. A label with the Modbus address is present inside the Modbus converters on the implemented module M-7002.

4-20 mA Modul:

Setting of the Channel for 4-20 mA sensors and full detectors:

Channel 0 is allocated to the terminal Vin0+ and DI0 (see electrical installation on page 9)

Channel 1 is allocated to the terminal Vin1+ and DI1

Channel 2 is allocated to the terminal Vin2+ and DI2

Channel 3 is allocated to the terminal Vin3+ and DI3

Full detector

If a full detector is connected, it is read with setting to "Modbus" (see electrical installation page 9 for connection to Modbus converter).

If "value" is selected, the message for full detection is activated, if the entered value (in percent) is exceeded by the material level.