

REVISIONS		
REV.	DATE	CO#
5	12/9/2005	23787
6	3/20/2010	34190

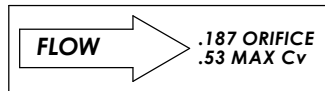
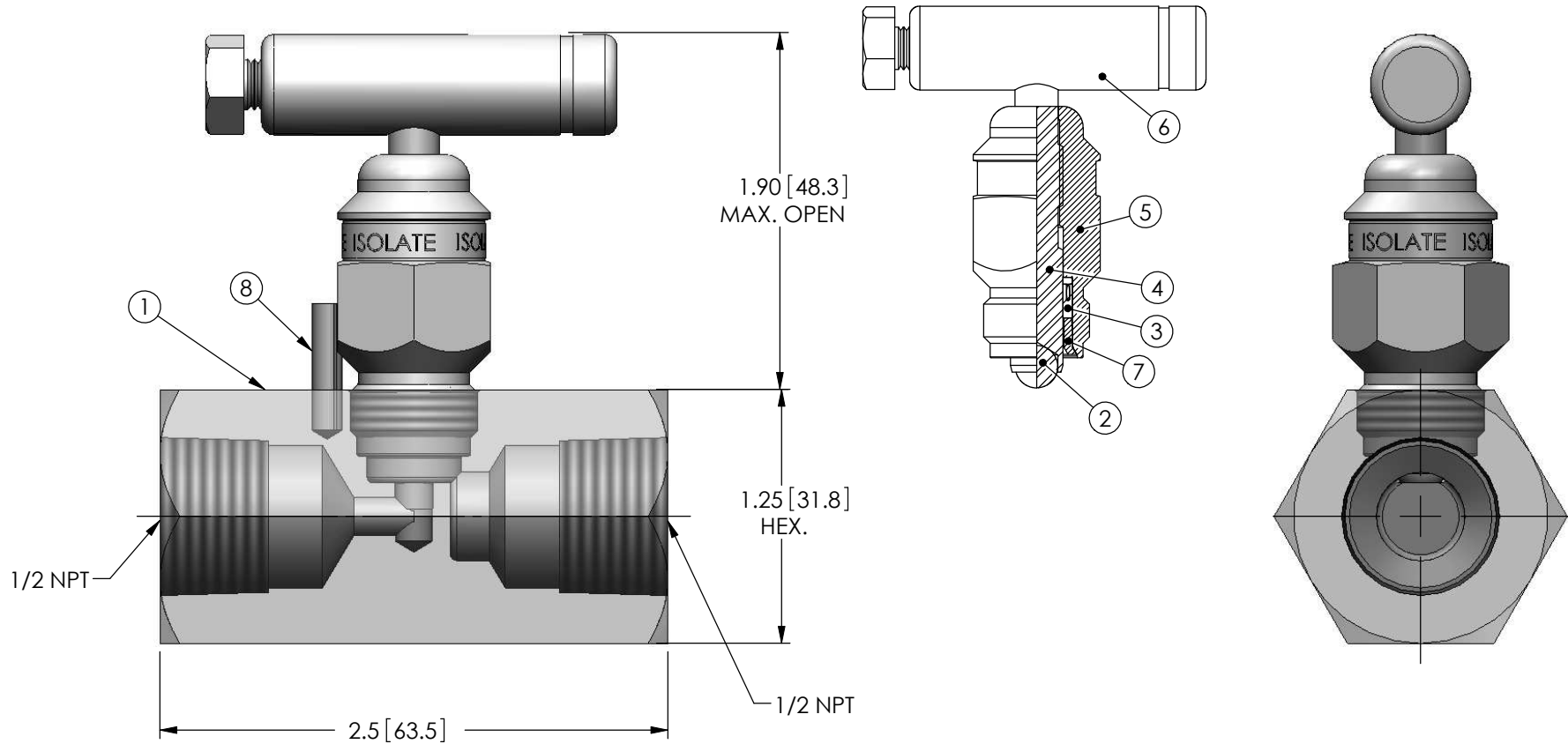

PRODUCT PART NUMBER		V-508CCT	V-508SCT	
NO.	DESCRIPTION	10,000 PSI @ 200°F 8,000 PSI @ 450°F MAX	10,000 PSI @ 200°F 8,000 PSI @ 450°F MAX	QTY.
1	VALVE BODY	(C) <AZ>ASTM A108	(S) ASTM A479-316	1
2	BALL (1/4" Ø)	(C) CARBIDE BALL	(C) CARBIDE BALL	1
3	STEM SEAL	(T) TEFLON	(T) TEFLON	1
4	STEM	ASTM A479-316	ASTM A479-316	1
5	BONNET	ASTM A108	ASTM A479-316	1
6	HANDLE ASSEMBLY	ASTM A108	300 SERIES SS	1
7	SEAL RETAINER	ASTM A479-316	ASTM A479-316	1
8	ROLL PIN	300 SERIES SS	300 SERIES SS	1

NOTES

1. DIMENSIONS IN [] ARE IN MILLIMETERS.
2. APPROX. WEIGHT X.X lbs. (X.X kg.)
3. <AZ> INDICATES ALKALINE ZINC PLATED WITH DICHROMATE DIP.
4. <P0> INDICATES PHOSPHATE AND OIL.
5. <P0> AISI 1018 C.S. IS USED WHEN WELDED BODY CONNECTION ARE SPECIFIED.
6. 316 SS MANIFOLD/VALVE MEETS REQUIREMENTS OF NACE MR0175/ISO 15156-3:2003 (LATEST REV.)

PGI RESERVES THE RIGHT TO CHANGE THE DESIGN, DIMENSIONS OR MATERIAL CONTENT OF OUR PRODUCTS WITHOUT PRIOR NOTIFICATION.



PGI International
Excellence Through Innovation

16101 VALLEN DRIVE HOUSTON, TX. 77041 (713) 466-0056 or 1-800-231-0233 FAX: (713) 744-9892

1/2F-F HARD SEAT VALVE

DRAWING NO. & REVISION

V-508XCT r06

PGI EXTERNAL DOCUMENT

GENERAL PRODUCT DESCRIPTION