

# SW26 Socket Weld 0.260" Bore Thermowell

## Model Code

SW26 - T1 - T2 - T3 - T4

### SW26 Stepped - 0.260" Bore - Socket Weld

T1	Process Connection	Nominal Pipe OD
3/4	3/4" NPS	1.050"
1	1" NPS	1.315"
Other Consult factory		

T2	Rating
3	Class 3000
6	Class 6000

T3	Material
304	304/304L stainless 800 Incoloy 800
316	316/316L stainless A105 A105 carbon steel
310	310 stainless steel LF2 A350 LF2
600	Inconel 600 HAC Hastelloy C276
625	Inconel 625 Other <sup>3</sup> Consult factory

T4	Specify "U" Length (inches)
"inches"	Specify length in inches

## Outline & Dimensions

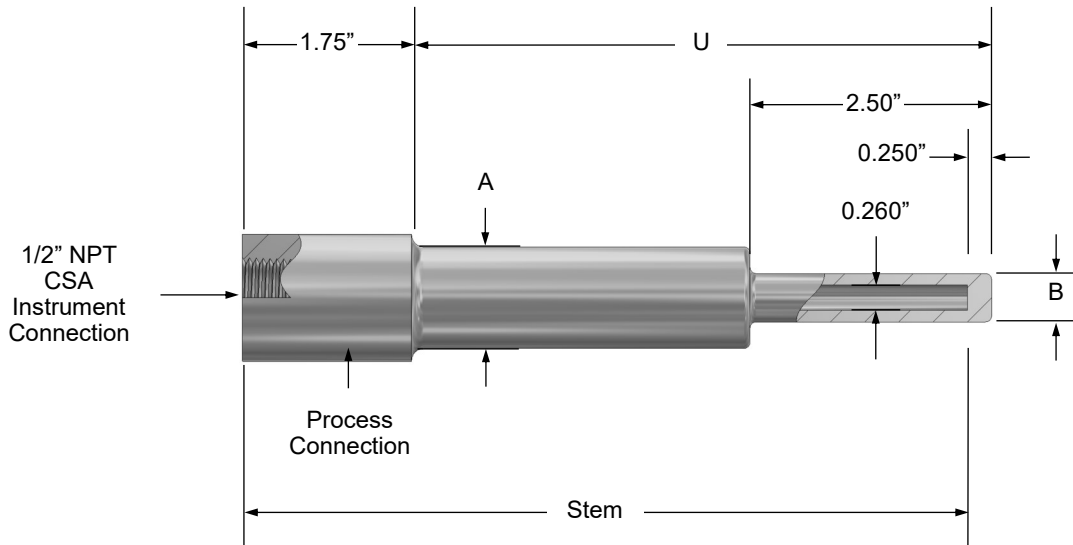

Process Connection	"A" Root OD		"B" Tip OD
	CL 3000	CL 6000	
3/4" NPS	0.750"	0.609"	0.500"
1" NPS	0.875"	0.750"	0.500"

### Special option codes specified as come complete with (c/w) thermowell if required

Code	Description
SSPC	Stainless steel plug and chain
BRPC	Brass plug and chain
OVRL	Overlay (details to be specified)

### NOTES:

- Part number example: SW26-3/4-3-LF2-4.5 or SW26-1-6-316-10.5 c/w SSPC
- Canadian Registration Number (CRN) available for most common alloys, consult factory

