

L1219A

Universal Explosion-proof LED Lighting

Warning Light (Steady on)



COB

Net Weight: 8.0 kg (17.6 lb)



Protection

- Ex d IIB + H₂ T6 Gb
- Ex tb IIIC T60°C...T80°C Db

Standards

JNIO SH-TR-46-1
JNIO SH-TR-46-2
JNIO SH-TR-46-9
IEC 60079-0
IEC 60079-1
IEC 60079-31

Light Features

- Salt spray 1000 hrs passed
- IP 68 rated for wet locations

Technical Data

Rated Voltage (±10%)	24V / 100V / 110V / 120V / 200V / 208V / 220V AC
Watts (±10%)	10W / 20W / 33W
Amps	10W 24V:0.42A, 100V:0.10A, 110V:0.09A, 120V:0.08A, 200V:0.05A, 208V: 0.048A, 220V: 0.045A 20W 24V:0.83A, 100V:0.20A, 110V:0.18A, 120V:0.17A, 200V:0.10A, 208V: 0.096A, 220V: 0.09A 33W 24V:1.38A, 100V:0.33A, 110V:0.30A, 120V:0.28A, 200V:0.17A, 208V: 0.16A, 220V: 0.15A
Color of LED Light	Red
Ambient Temperature	-20°C ~ +40°C, T6
Power Factor	cos ≥ 0.9
Beam Angle	X-110° / Y-110°
Frequency	50 / 60 Hz
Degree of Protection	IP68 / NEMA 6P
Material	• Enclosure • Glass Aluminum alloy Tempered glass
LED Service Life	60,000 hrs
Entrance Thread	G 3/4" × 4 (Tall top cover) G 3/4" × 1 (Short top cover)

Tall Top Cover

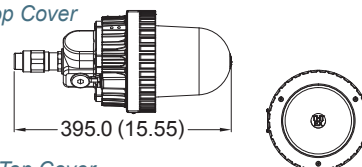

Short Top Cover

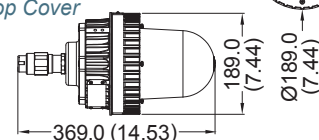

Dimension in Millimeters (inches)

Model Code

THT-EX	1219	R	E	S	B	1	1	C90
Brand, THT=Top Hi-Tech Co, Ltd.	Model Name, 1219=Model L1219	C.C.T., R=Red light	Voltage, A=24V, B=100V, C=110V, D=200V, E=220V, F=120V, G=208V	Type of LED carrier, S=Short Cylinder	Type of Top Cover, A=Tall type, B=Short type	LED quantity, 1=1 LED	Wattage, 1=10W, 2=20W, 3=33W	Mounting bracket type W25/90=Wall Mount 25°/90° H25/90=Hanging Mount 25°/90° S25/90=Stanchion 25°/90° P30=Pendant C90=Ceiling

Mounting Option & Dimensions (All in mm)

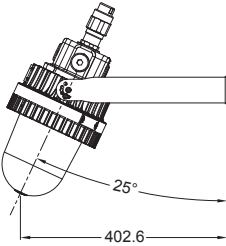
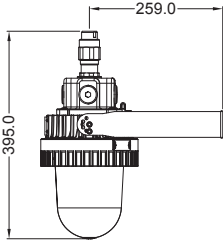
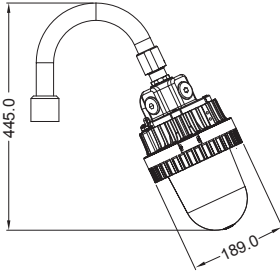
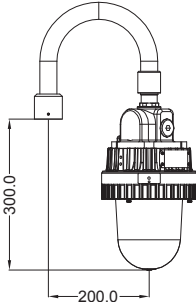
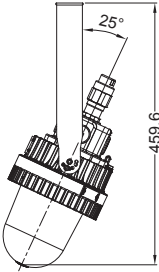
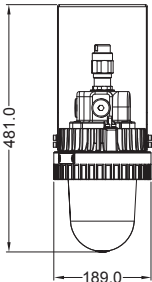
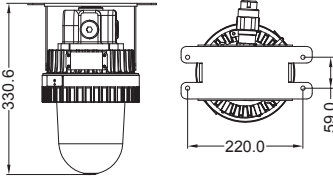
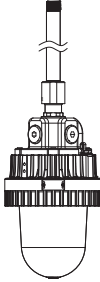

Tall Top Cover (Standard Product)

<p>Wall Mount 25° (W25)</p>  <p>8.4 kg (18.5 lb)</p>	<p>Wall Mount 90° (W90)</p>  <p>8.4 kg (18.5 lb)</p>	<p>Stanchion 25° (S25)</p>  <p>9.3 kg (20.5 lb)</p>	<p>Stanchion 90° (S90)</p>  <p>9.1 kg (20.0 lb)</p>
<p>Hanging Mount 25° (H25)</p>  <p>8.4 kg (18.5 lb)</p>	<p>Hanging Mount 90° (H90)</p>  <p>8.4 kg (18.5 lb)</p>	<p>Ceiling (C90)</p>  <p>8.7 kg (19.1 lb)</p>	<p>Pendant (P30)</p>  <p>8.4 kg (18.5 lb)</p>

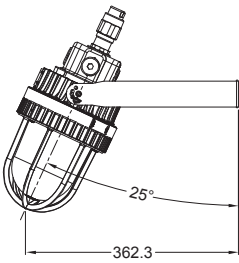
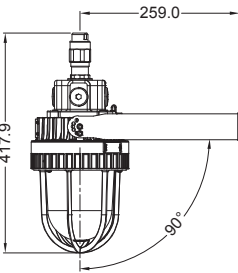
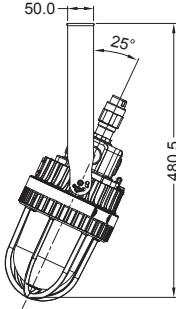
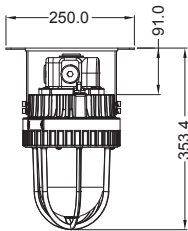
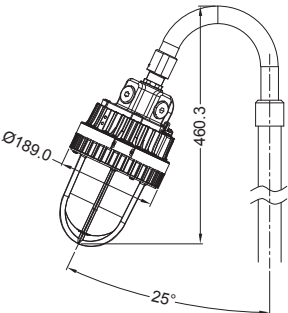
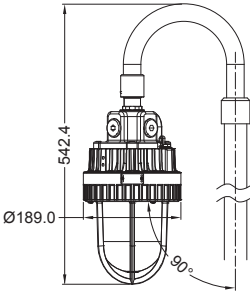
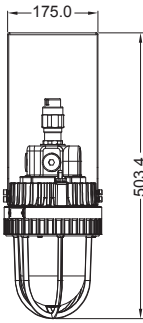
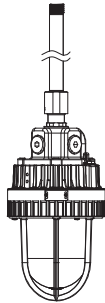
Tall Top Cover (With Accessory "Guard")

<p>Wall Mount 25° (W25G)</p>  <p>8.6 kg (18.9 lb)</p>	<p>Wall Mount 90° (W90G)</p>  <p>8.6 kg (18.9 lb)</p>	<p>Hanging Mount 25° (H25G)</p>  <p>8.6 kg (18.9 lb)</p>	<p>Ceiling (C90G)</p>  <p>8.9 kg (19.5 lb)</p>
<p>Stanchion 25° (S25G)</p>  <p>9.5 kg (20.9 lb)</p>	<p>Stanchion 90° (S90G)</p>  <p>9.3 kg (20.5 lb)</p>	<p>Hanging Mount 90° (H90G)</p>  <p>8.6 kg (18.9 lb)</p>	<p>Pendant (P90G)</p>  <p>8.6 kg (18.9 lb)</p>

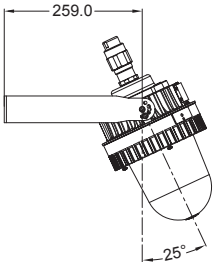
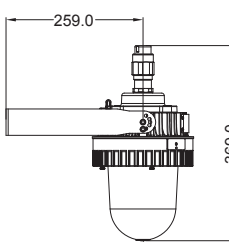
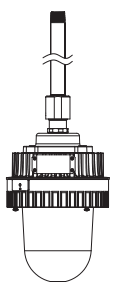
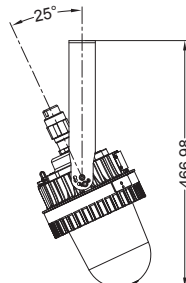
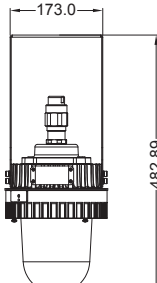
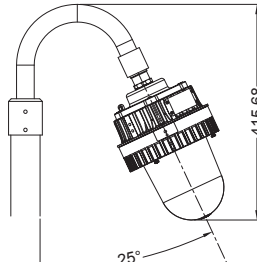
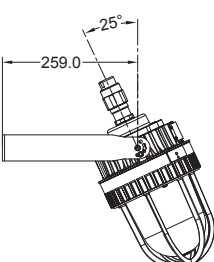
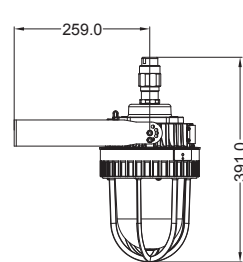
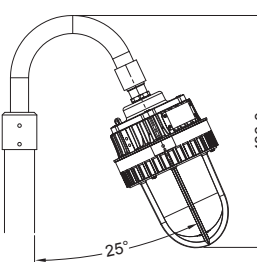
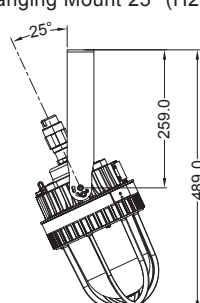
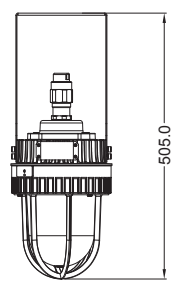
Mounting Option & Dimensions (All in mm)

Short Top Cover (Standard Product)		
<p>Wall Mount 25° (W25)</p>  <p>7.8 kg (17.2 lb)</p>	<p>Wall Mount 90° (W90)</p>  <p>7.8 kg (17.2 lb)</p>	<p>Pendant (P30)</p>  <p>7.8 kg (17.2 lb)</p>
<p>Hanging Mount 25° (H25)</p>  <p>7.8 kg (17.2 lb)</p>	<p>Hanging Mount 90° (H90)</p>  <p>7.8 kg (17.2 lb)</p>	<p>Stanchion 25° (S25)</p>  <p>8.7 kg (19.1 lb)</p>
Short Top Cover (With Accessory "Guard")		
<p>Wall Mount 25° (W25G)</p>  <p>8.0 kg (17.6 lb)</p>	<p>Wall Mount 90° (W90G)</p>  <p>8.0 kg (17.6 lb)</p>	<p>Stanchion 25° (S25G)</p>  <p>8.9 kg (19.5 lb)</p>
<p>Hanging Mount 25° (H25G)</p>  <p>8.0 kg (17.6 lb)</p>	<p>Hanging Mount 90° (H90G)</p>  <p>8.0 kg (17.6 lb)</p>	<p>Pendant (P30G)</p>  <p>8.0 kg (17.6 lb)</p>

Applicable Area

- Oil Refinery Complex
- Petrochemical Complex
- Painting Facility
- Transporting Nature Gas
- Transporting Liquefied
- Petroleum Gas
- Offshore Platform (Oil and Natural Gas)