

L1219A

Universal Explosion-proof LED Lighting

Warning Light (Steady on)



COB

Net Weight: 8.0 kg (17.6 lb)

Zone 1
Zone 2
Zone 21
Zone 22
IP68
NEMA 6P

Protection

- Ex d IIB + H₂ T6 Gb
- Ex tb IIIC T60°C...T80°C Db
- Ⓜ II 2 G Ex d IIB+H₂ T6 Gb
- Ⓜ II 2 D Ex tb IIIC T60°C... 80°C Db

Standards

- IEC 60079-0
- IEC 60079-1
- IEC 60079-31
- EN 60079-0
- EN 60079-1
- EN 60079-31

Light Features

- Salt spray 1000 hrs passed
- IP 68 rated for wet locations

Technical Data

Rated Voltage (±10%)	220V AC
Watts (±10%)	10W / 20W
Amps	10W 220V: 0.05A / 20W 220V: 0.09A
Color of LED Light	Red
Ambient Temperature	-20°C ~ +40°C, T6
Power Factor	cos ≥ 0.9
Beam Angle	X-110° / Y-110°
Frequency	50 / 60 Hz
Degree of Protection	IP68 / NEMA 6P
Material	<ul style="list-style-type: none"> • Enclosure: Aluminum alloy • Glass: Tempered glass
LED Service Life	60,000 hrs
Entrance Thread	G 3/4" × 4 (Tall top cover) G 3/4" × 1 (Short top cover)

Tall Top Cover

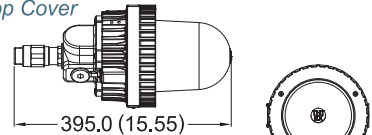

Short Top Cover

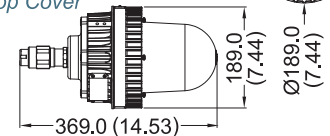

Dimension in Millimeters (inches)

Model Code

THT-EX
1219
R
E
S
B
1
1
C90

- Brand, THT=Top Hi-Tech Co, Ltd.
- Model Name, 1219=Model L1219
- C.C.T., R=Red light
- Voltage, E=220V
- Type of LED carrier, S=Short Cylinder
- Type of Top Cover, A=Tall type, B=Short type
- LED quantity, 1=1 LED
- Wattage, 1=10W, 2=20W
- Mounting bracket type
 W25/90=Wall Mount 25°/90°
 H25/90=Hanging Mount 25°/90°
 S25/90=Stanchion 25°/90°
 P30=Pendant
 C90=Ceiling

Mounting Option & Dimensions (All in mm)



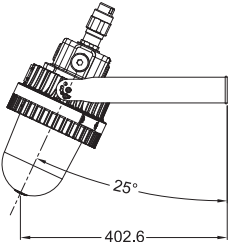
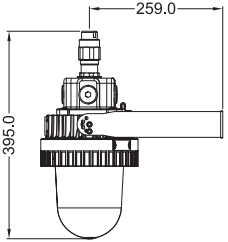
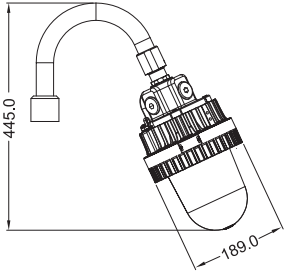
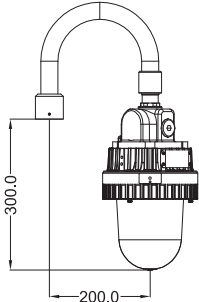
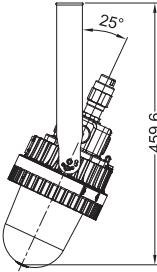
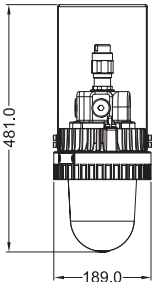
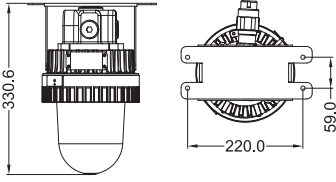
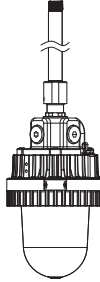

Tall Top Cover (Standard Product)

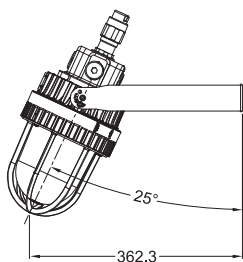
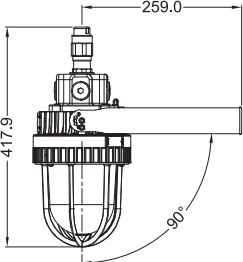
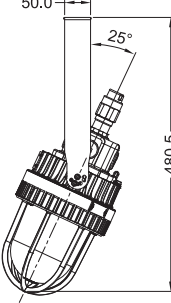
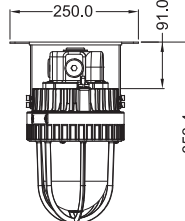
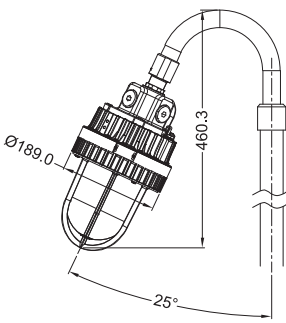
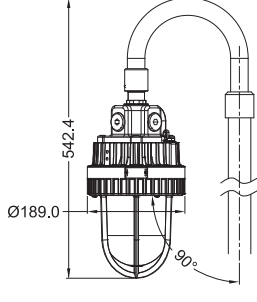
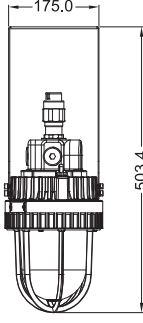
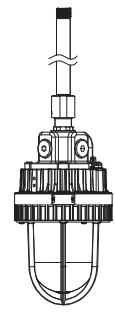
<p>Wall Mount 25° (W25)</p>  <p>8.4 kg (18.5 lb)</p>	<p>Wall Mount 90° (W90)</p>  <p>8.4 kg (18.5 lb)</p>	<p>Stanchion 25° (S25)</p>  <p>9.3 kg (20.5 lb)</p>	<p>Stanchion 90° (S90)</p>  <p>9.1 kg (20.0 lb)</p>
<p>Hanging Mount 25° (H25)</p>  <p>8.4 kg (18.5 lb)</p>	<p>Hanging Mount 90° (H90)</p>  <p>8.4 kg (18.5 lb)</p>	<p>Ceiling (C90)</p>  <p>8.7 kg (19.1 lb)</p>	<p>Pendant (P30)</p>  <p>8.4 kg (18.5 lb)</p>

Tall Top Cover (With Accessory "Guard")

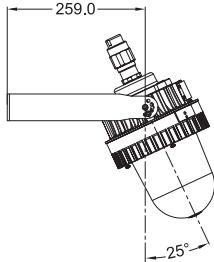
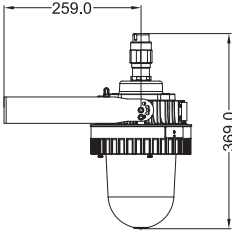
<p>Wall Mount 25° (W25G)</p>  <p>8.6 kg (18.9 lb)</p>	<p>Wall Mount 90° (W90G)</p>  <p>8.6 kg (18.9 lb)</p>	<p>Hanging Mount 25° (H25G)</p>  <p>8.6 kg (18.9 lb)</p>	<p>Ceiling (C90G)</p>  <p>8.9 kg (19.5 lb)</p>
<p>Stanchion 25° (S25G)</p>  <p>9.5 kg (20.9 lb)</p>	<p>Stanchion 90° (S90G)</p>  <p>9.3 kg (20.5 lb)</p>	<p>Hanging Mount 90° (H90G)</p>  <p>8.6 kg (18.9 lb)</p>	<p>Pendant (P90G)</p>  <p>8.6 kg (18.9 lb)</p>

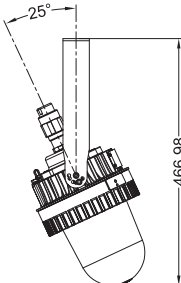
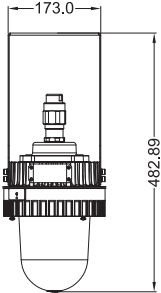
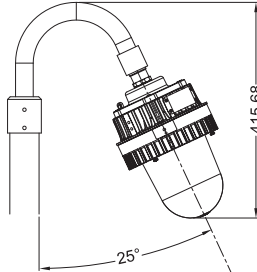
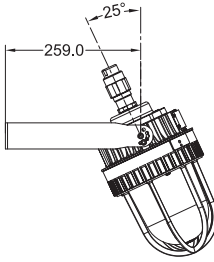
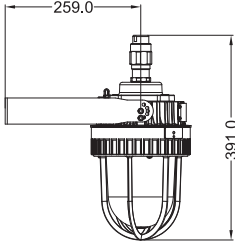
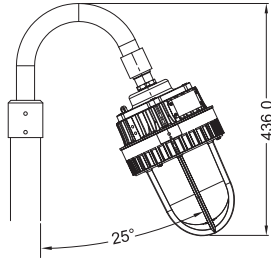
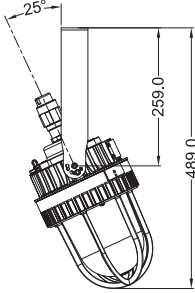
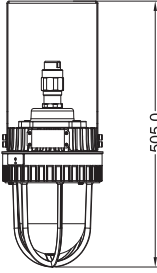
Mounting Option & Dimensions (All in mm)

Short Top Cover (Standard Product)		
<p>Wall Mount 25° (W25)</p>  <p>7.8 kg (17.2 lb)</p>	<p>Wall Mount 90° (W90)</p>  <p>7.8 kg (17.2 lb)</p>	<p>Pendant (P30)</p>  <p>7.8 kg (17.2 lb)</p>
<p>Hanging Mount 25° (H25)</p>  <p>7.8 kg (17.2 lb)</p>	<p>Hanging Mount 90° (H90)</p>  <p>7.8 kg (17.2 lb)</p>	<p>Stanchion 25° (S25)</p>  <p>8.7 kg (19.1 lb)</p>
Short Top Cover (With Accessory "Guard")		
<p>Wall Mount 25° (W25G)</p>  <p>8.0 kg (17.6 lb)</p>	<p>Wall Mount 90° (W90G)</p>  <p>8.0 kg (17.6 lb)</p>	<p>Stanchion 25° (S25G)</p>  <p>8.9 kg (19.5 lb)</p>
<p>Hanging Mount 25° (H25G)</p>  <p>8.0 kg (17.6 lb)</p>	<p>Hanging Mount 90° (H90G)</p>  <p>8.0 kg (17.6 lb)</p>	<p>Pendant (P30G)</p>  <p>8.0 kg (17.6 lb)</p>

Applicable Area

- Oil Refinery Complex
- Petrochemical Complex
- Painting Facility
- Transporting Nature Gas
- Transporting Liquefied
- Petroleum Gas
- Offshore Platform (Oil and Natural Gas)