

REVISIONS		
REV.	DATE	CO#
3	10/22/2005	23303

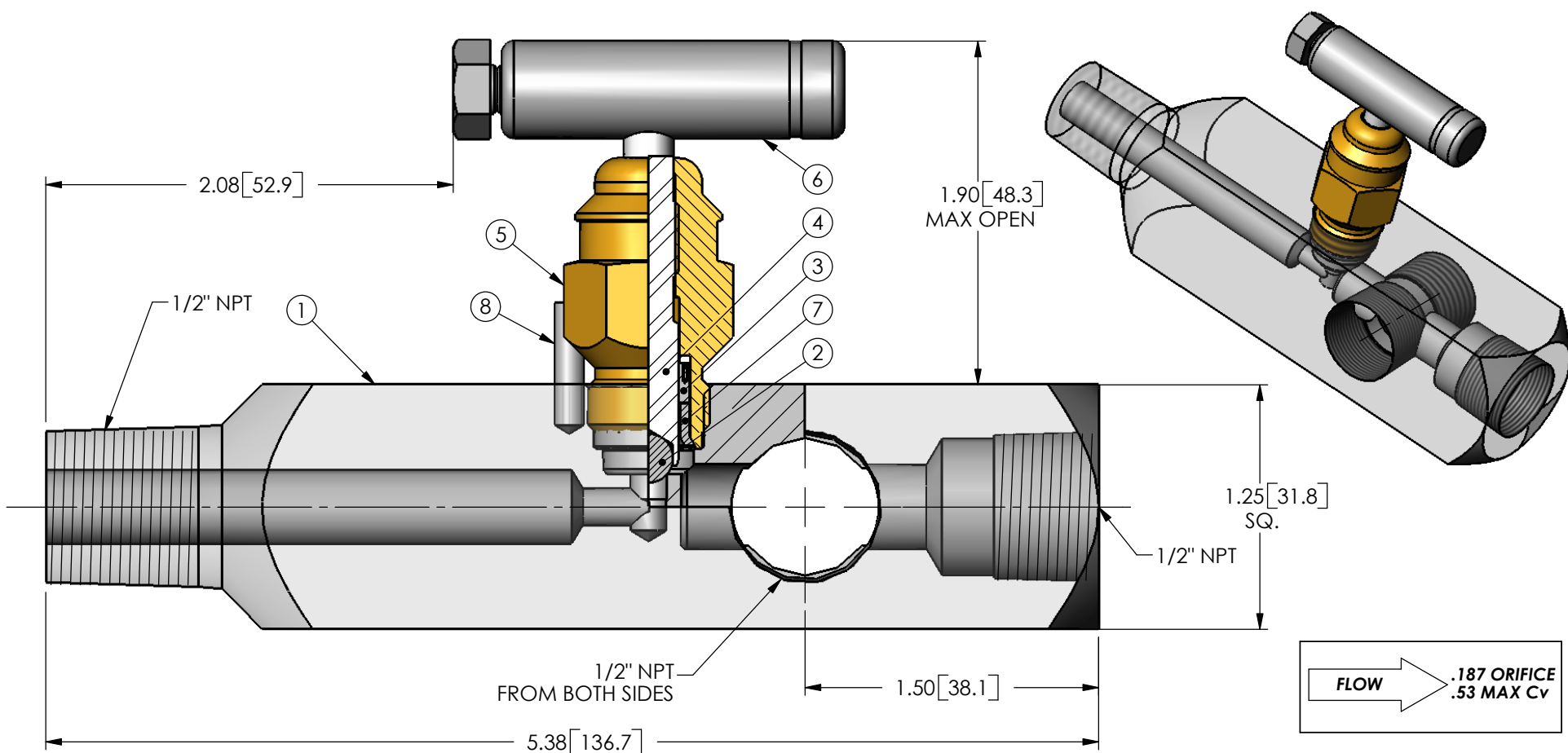

**FLOW**  
 .187 ORIFICE  
 .53 MAX Cv

**NOTES**

1. DIMENSIONS IN [ ] ARE IN MILLIMETERS.
2. APPROX. WEIGHT 2.3 lbs. (1.0 kg.)
3. <AZ> INDICATES ALKALINE ZINC PLATED WITH DICHROMATE DIP.
4. <PO> INDICATES PHOSPHATE AND OIL.
5. <P0> AISI 1018 C.S. IS USED WHEN WELDED BODY CONNECTION ARE SPECIFIED.
6. 316 SS MANIFOLD/VALVE MEETS REQUIREMENTS OF NACE MR0175 (LATEST REV.) UP TO 140°F

PGI RESERVES THE RIGHT TO CHANGE THE DESIGN, DIMENSIONS OR MATERIAL CONTENT OF OUR PRODUCTS WITHOUT PRIOR NOTIFICATION.

**PGI International**

16101 VALLEN DRIVE (713) 466-0056 or 1-800-231-0233  
 HOUSTON, TX. 77041 FAX: (713) 744-9892

**1/2 M-F HARD SEAT  
MULTI-PORT VALVE**

APP'D	DRAWING NO. & REVISION
SCALE <b>NONE</b>	<b>V-516XCT r03</b>

**PGI EXTERNAL DOCUMENT  
GENERAL PRODUCT DESCRIPTION**

PRODUCT PART NUMBER		V-516CCT	V-516SCT	
NO.	DESCRIPTION	10,000 PSI @ 200°F 8,000 PSI @ 450°F MAX	10,000 PSI @ 200°F 8,000 PSI @ 450°F MAX	QTY.
1	VALVE BODY	(C) <AZ>ASTM A108-1215	(S) ASTM A479-316	1
2	BALL (1/4")	(C) CARBIDE BALL	(C) CARBIDE BALL	1
3	STEM SEAL	(T) TEFLON	(T) TEFLON	1
4	STEM	ASTM A479-316	ASTM A479-316	1
5	BONNET	<AZ> ASTM A108-1215	ASTM A479-316	1
6	HANDLE ASSEMBLY	<AZ>ASTM A108	ASTM A582 18-8	1
7	SEAL RETAINER	ASTM A479-316	ASTM A479-316	1
8	ROLL PIN	300 SERIES SS	300 SERIES SS	1